



# Product Data

## Wall-Mount Air Handlers 2 – 3 Ton

TMM5B0B24M21SA

TMM5B0B30M21SA

TMM5B0B36M31SA

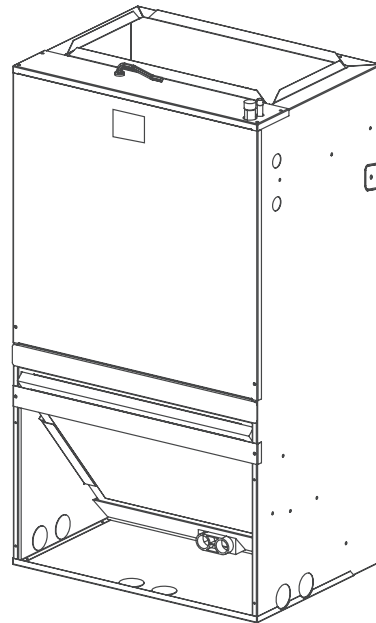

**Note:** "Graphics in this document are for representation only.  
Actual model may differ in appearance."



**TRANE®**

# Features and Accessories

---

## STANDARD FEATURES

- Front or bottom return air
- Painted finish on galvanized steel
- Sturdy polycarbonate drain pans
  - The TMM5 wall mount air handler has factory installed drain pans and is shipped for upflow applications only.
- 208/230 VAC operation
- Multi-speed direct drive blower
  - Constant torque ECM motor with fan-off time delay programming
- Factory installed R-410A thermal expansion valve
- Stud or wall mounting tabs
- Fully insulated cabinet
- 3/4" NPT primary and secondary drains
- **3 year warranty**
- **10-year warranty registered**
- **Optional extended warranty available**

## OPTIONAL ACCESSORIES

- 5, 7.5, and 10 kW single phase electric heaters
  - Circuit breakers are standard on all single phase 5, 7.5, and 10 kW heaters.



# Contents

---

<b>Features and Accessories</b>	<b>2</b>
<b>Performance Data</b>	<b>4</b>
<b>Electrical Data</b>	<b>7</b>
<b>Dimensions</b>	<b>10</b>
<b>Field Wiring</b>	<b>11</b>



**TRANE®**

# Performance Data

## Heater Pressure Drop Table – Use for all TMM5 air handler models

MODEL	AIRFLOW CFM	NUMBER OF RACKS		
		1	2	3
		AIR PRESSURE DROP - INCHES W.G.		
TMM5B0B30, 36	1400	0.06	0.08	0.08
	1300	0.06	0.08	0.08
	1200	0.06	0.08	0.08
	1100	0.06	0.08	0.08
	1000	0.06	0.08	0.08
	900	0.04	0.06	0.06
	800	0.04	0.06	0.06
TMM5B0B24	900	0.04	0.06	0.06
	800	0.04	0.06	0.06
	700	0.04	0.06	0.06
	600	0.04	0.06	0.06

### Accessory Heater Usage

NUMBER OF RACKS	SIZES USED WITH	kW	INTERNAL CIRCUIT PROTECTION
1	24-36	5	Circuit Breaker
2	24-36	7.5	Circuit Breaker
3	24-36	10	Circuit Breaker

### HEATER RACKS

HEATER MODEL	NO. OF RACKS
BAYHTRM505BRKA	1
BAYHTRM505BRKA	2
BAYHTRM505BRKA	3

### Minimum CFM

MODEL	NUMBER OF RACKS		
	1	2	3
TMM5B0B24M21SA	575	600	625
TMM5B0B30M21SA	575	600	625
TMM5B0B36M31SA	700	725	750



# Performance Data

## Performance and Electrical Data

### AIR FLOW PERFORMANCE (Standard CFM)

MODEL SIZE	BLOWER SPEEDS	EXTERNAL STATIC PRESSURE (INWC.)								
		0	0.1	0.2	0.3	0.4	0.5	0.6	0.7	0.8
TMM5B0B24M21SA	TAP 5	1014	961	925	877	836	777	742	685	637
	TAP 4 - Factory	830	776	737	677	636	569	510	478	426
	TAP 3	814	773	724	680	626	556	509	464	426
	* TAP 2	683	575	475	391	324	284	227	171	/
	TAP 1	655	540	388	227	147	/	/	/	/
TMM5B0B30M21SA	TAP 5	1252	1214	1182	1144	1113	1072	1019	957	883
	TAP 4	1149	1117	1077	1042	1007	973	938	893	841
	TAP 3	1125	1094	1054	1023	983	951	909	864	827
	TAP 2 - Factory	1036	1003	962	929	891	857	812	766	719
	TAP 1	959	912	879	838	808	752	695	651	593
TMM5B0B36M31SA	TAP 5	1252	1214	1182	1144	1113	1072	1019	957	883
	TAP 4 - Factory	1149	1117	1077	1042	1007	973	938	893	841
	TAP 3	1125	1094	1054	1023	983	951	909	864	827
	TAP 2	1036	1003	962	929	891	857	812	766	719
	TAP 1	959	912	879	838	808	752	695	651	593

Shaded boxes represent airflow outside the required 300-400 cfm/ton.

\* When TMM5B0B24MM21SA uses the 18 KBTU outdoor unit, select SCFM between 450 and 675.

#### NOTES:

1. Airflow based upon dry coil at 230V with no electric heat, no filter. For 24, 30, and 36 sizes, airflow at 208V is approximately the same as 230V because the multi-tap ECM motor is a constant torque motor. The torque doesn't drop off at the speeds in which the motor operates.
2. Airflow is equivalent for front or bottom return configurations.
3. SCFM is nearly the same with cooling performance airflow, the gap is in the 1 to 2%.



**TRANE®**

# Performance Data

## TMM5 AIR HANDLER AND HEATER MATRIX – ALLOWABLE COMBINATIONS

TMM5 MINIMUM HEATER AIRFLOW CFM – HEATER MATRIX			
Model No.	BAYHTRM505BRKA	BAYHTRM508BRKA	BAYHTRM510BRKA
TMM5B0B24M21SA	Tap4 / Tap5	Tap4 / Tap5	Tap4 / Tap5
TMM5B0B30M21SA	Tap2 / Tap3	Tap2 / Tap3	Tap2 / Tap3
TMM5B0B36M31SA	Tap4 / Tap3	Tap4 / Tap3	Tap4 / Tap3
Cooling / HP Airflow			

## TMM5 AIR HANDLER AND HEATER ELECTRICAL DATA

ELECTRICAL DATA											
TMM5B0B24M21SA											
Heater Model No	No. of Circuits/ Phases	240 Volt					208 Volt				
		Capacity		Heater Amps per Circuit	Minimum Circuit Ampacity	Maximum Overload Protection	Capacity		Heater Amps per Circuit	Minimum Circuit Ampacity	Maximum Overload Protection
		kW	BTUH				kW	BTUH			
No Heater					3.5	15				3.5	15
BAYHTRM505BRKA	1/1	5	17100	20.8	28.5	30	3.8	12800	18.0	25.0	30
BAYHTRM508BRKA	1/1	7.5	25600	31.2	41.5	45	5.6	19200	27.1	36.3	40
BAYHTRM510BRKA	1/1	10	34100	41.7	54.5	60	7.5	25600	36.1	47.6	50

ELECTRICAL DATA											
TMM5B0B30M21SA											
Heater Model No	No. of Circuits/ Phases	240 Volt					208 Volt				
		Capacity		Heater Amps per Circuit	Minimum Circuit Ampacity	Maximum Overload Protection	Capacity		Heater Amps per Circuit	Minimum Circuit Ampacity	Maximum Overload Protection
		kW	BTUH				kW	BTUH			
No Heater					5.2	15				5.2	15
BAYHTRM505BRKA	1/1	5	17100	20.8	29.5	30	3.8	12800	18.0	26.0	30
BAYHTRM508BRKA	1/1	7.5	25600	31.2	42.5	45	5.6	19200	27.1	37.3	40
BAYHTRM510BRKA	1/1	10	34100	41.7	55.5	60	7.5	25600	36.1	48.6	50

ELECTRICAL DATA											
TMM5B0B36M31SA											
Heater Model No	No. of Circuits/ Phases	240 Volt					208 Volt				
		Capacity		Heater Amps per Circuit	Minimum Circuit Ampacity	Maximum Overload Protection	Capacity		Heater Amps per Circuit	Minimum Circuit Ampacity	Maximum Overload Protection
		kW	BTUH				kW	BTUH			
No Heater					5.2	15				5.2	15
BAYHTRM505BRKA	1/1	5	17100	20.8	29.5	30	3.8	12800	18.0	26.0	30
BAYHTRM508BRKA	1/1	7.5	25600	31.2	42.5	45	5.6	19200	27.1	37.3	40
BAYHTRM510BRKA	1/1	10	34100	41.7	55.5	60	7.5	25600	36.1	48.6	50

# Electrical Data

## Wiring diagram for TMM5B0B24M21SA

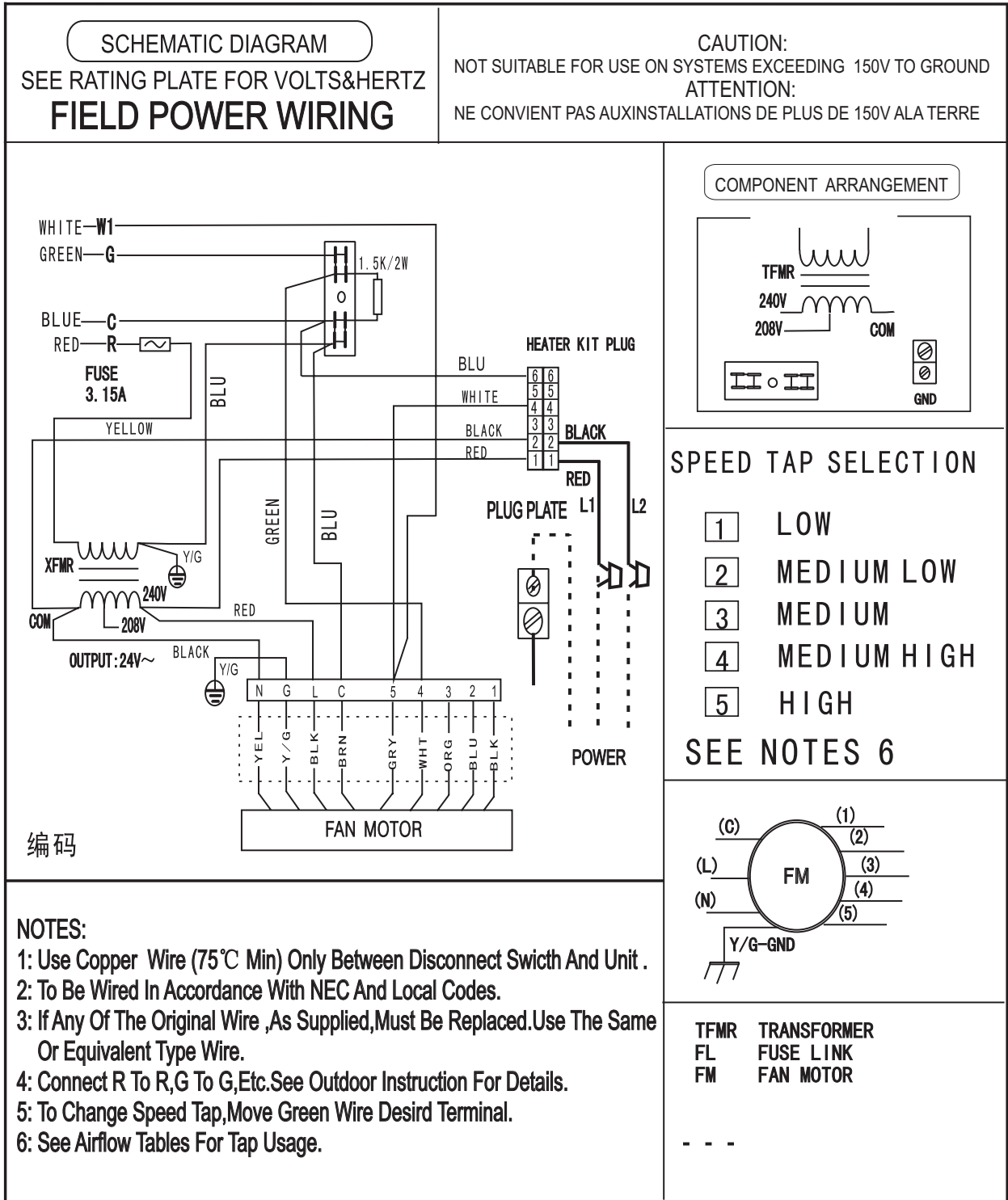

TMM5B0B24M21SAA



**TRANE®**

# Electrical Data

## Wiring diagram for TMM5B0B30M21SA

### SCHEMATIC DIAGRAM

SEE RATING PLATE FOR VOLTS&HERTZ  
**FIELD POWER WIRING**

**CAUTION:**  
NOT SUITABLE FOR USE ON SYSTEMS EXCEEDING 150V TO GROUND  
**ATTENTION:**  
NE CONVIENT PAS AUX INSTALLATIONS DE PLUS DE 150V A LA TERRE

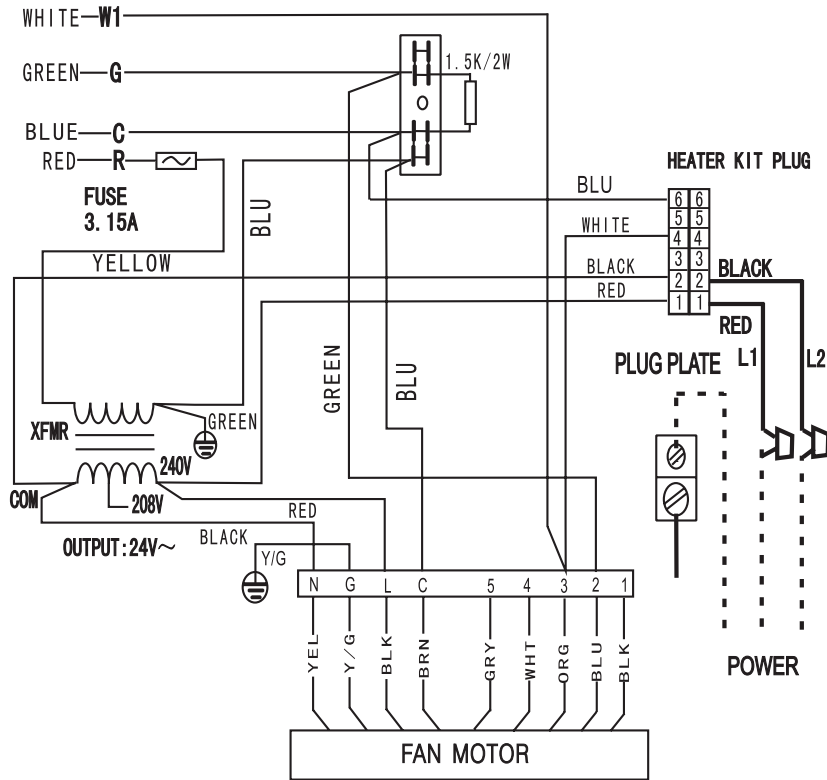

### COMPONENT ARRANGEMENT

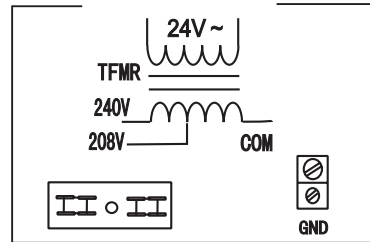

### SPEED TAP SELECTION

- 1 LOW
- 2 MEDIUM LOW
- 3 MEDIUM
- 4 MEDIUM HIGH
- 5 HIGH

SEE NOTES 6

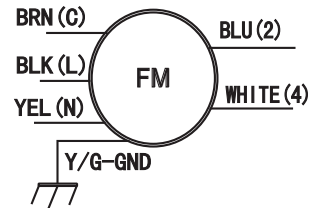

### NOTES:

- 1: Use Copper Wire (75°C Min) Only Between Disconnect Switch And Unit .
- 2: To Be Wired In Accordance With NEC And Local Codes.
- 3: If Any Of The Original Wire ,As Supplied,Must Be Replaced.Use The Same Or Equivalent Type Wire.
- 4: Connect R To R,G To G,Etc.See Outdoor Instruction For Details.
- 5: To Change Speed Tap,Move Blue Wire Desird Terminal.
- 6: See Airflow Tables For Tap Usage.
- 7:Factory Wires May Be Present,DO NOT USE.

TFMR TRANSFORMER  
 FL FUSE LINK  
 FM FAN MOTOR  
 CAP FAN CAPACITOR  
 GND GROUND  
 - - - FIELD POWER WIRING

TMM5B0B30M21SAA



# Electrical Data

## Wiring diagram for TMM5B0B36M31SA

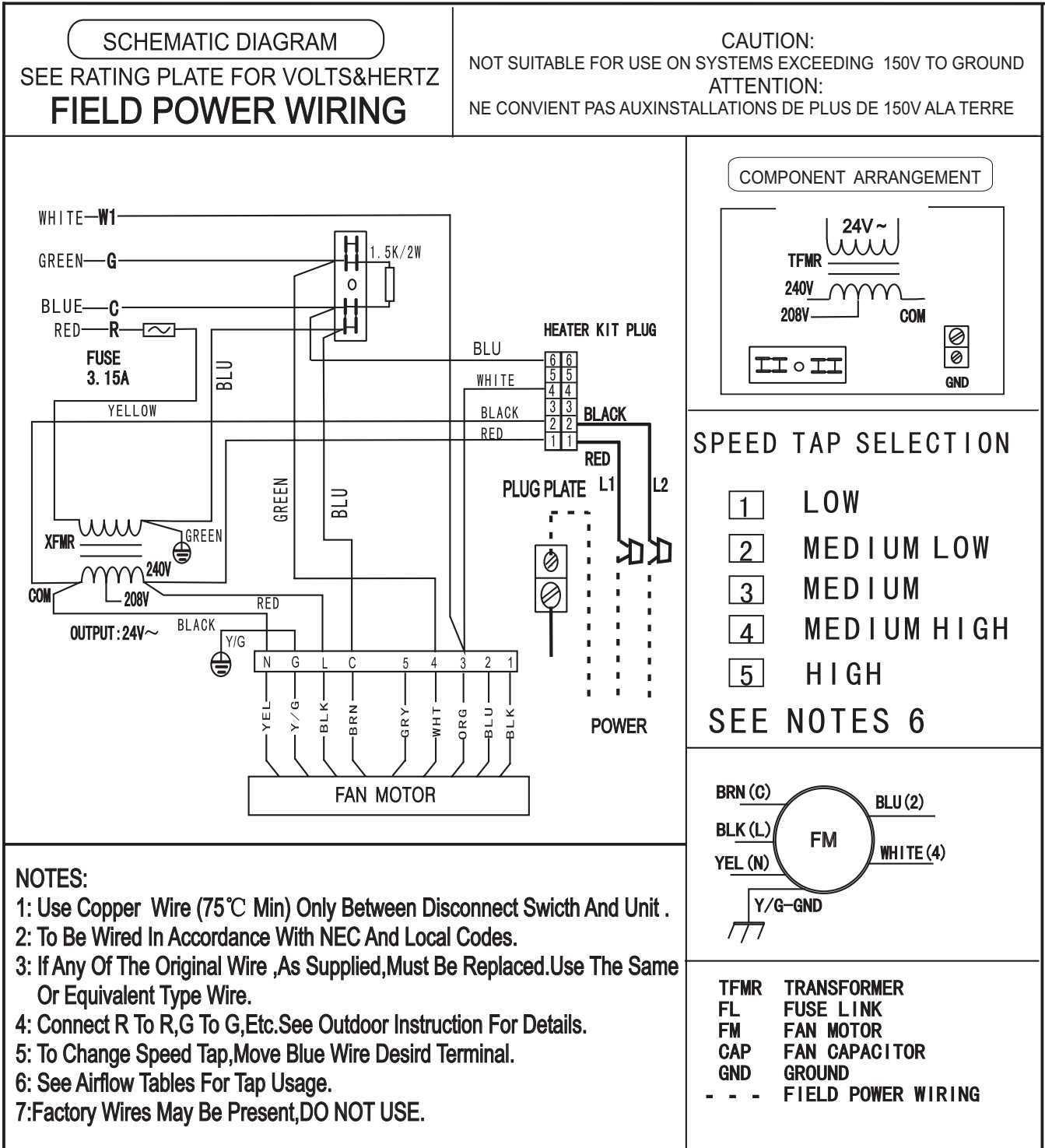

TMM5B0B36M31SAA

# Dimensions

## TMM5 AIR HANDLER DIMENSIONAL DATA

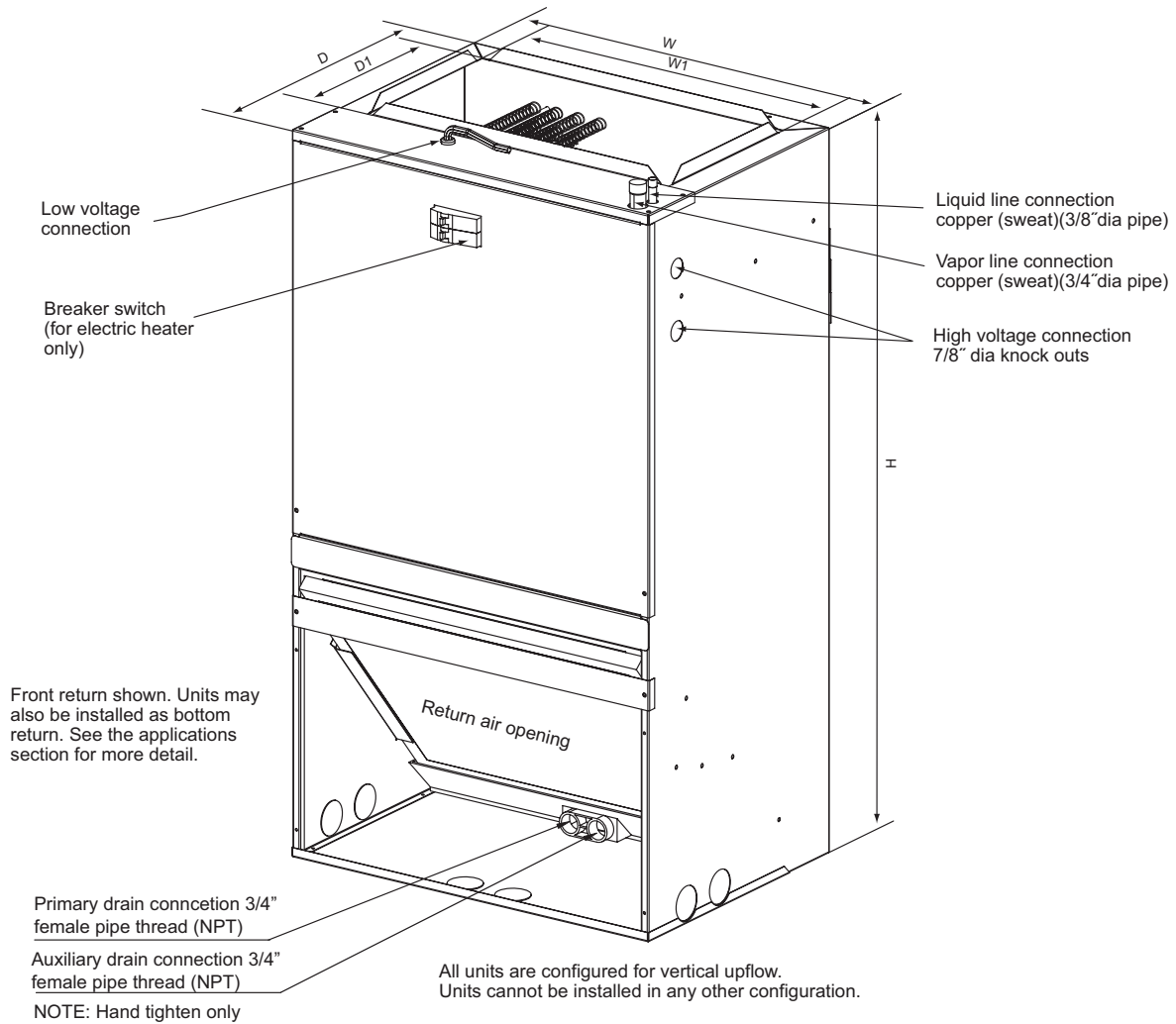

### DIMENSIONAL DATA

Model	Dimensions inch [mm]						Flow Control	Gas Line Braze	UNIT WEIGHT /SHIPPING WEIGHT (LBS.[kg])
	H	W	W1	D	D1				
TMM5B0B24M21SAA	39-1/2" [1004]	22" [559]	18-3/4" [477]	19" [483]	9-1/2" [242]	TXV	3/4"	101/115 [46]/[52]	
TMM5B0B30M21SAA	39-1/2" [1004]	22" [559]	18-3/4" [477]	19" [483]	9-1/2" [242]	TXV	3/4"	104/117 [47]/[53]	
TMM5B0B36M31SAA	39-1/2" [1004]	22" [559]	18-3/4" [477]	19" [483]	9-1/2" [242]	TXV	3/4"	104/117 [47]/[53]	

# Field Wiring

## TMM5 AIR HANDLERS FIELD WIRING DIAGRAMS

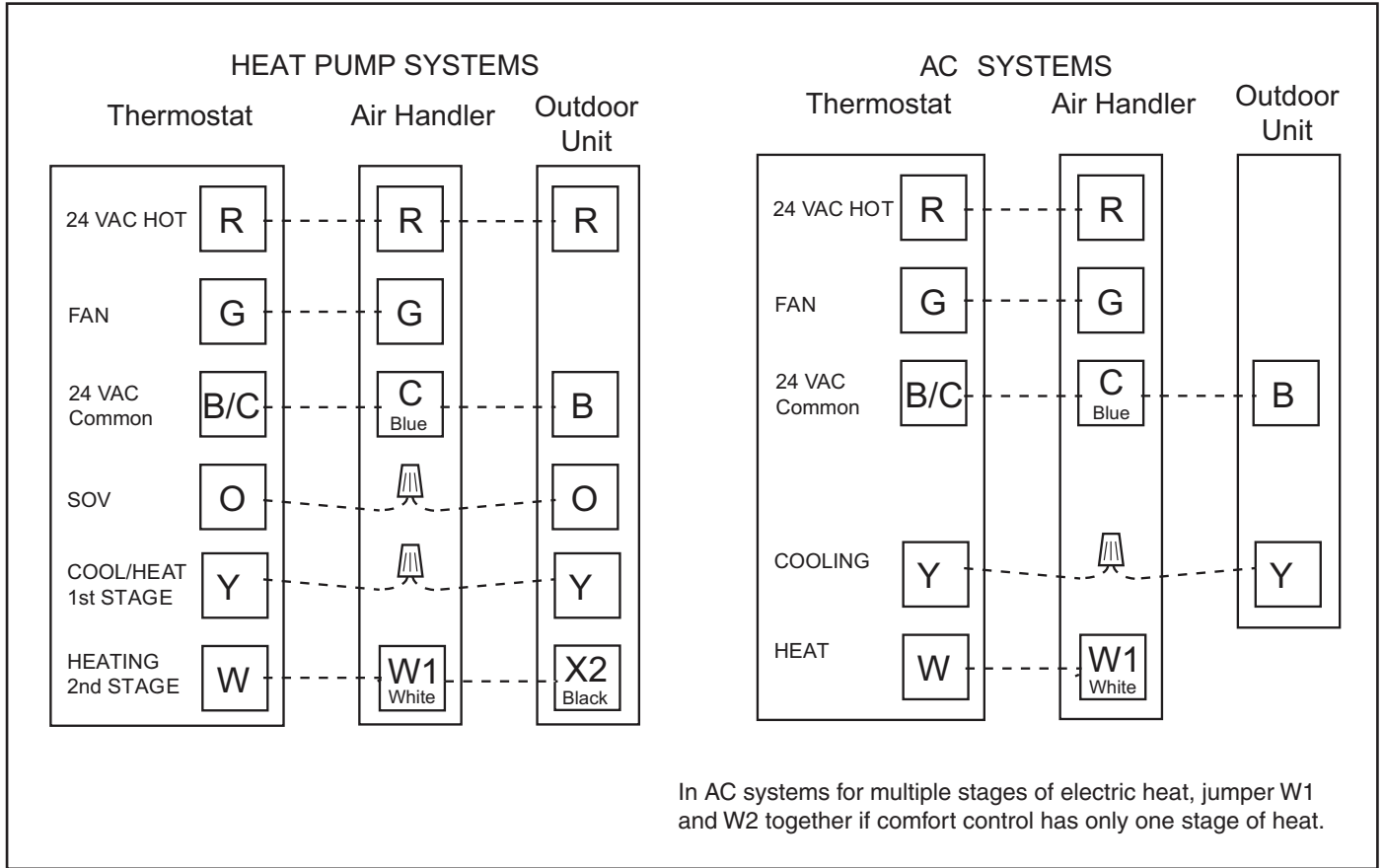



Trane - by Trane Technologies (NYSE: TT), a global climate innovator - creates comfortable, energy efficient indoor environments for commercial and residential applications. For more information, please visit [trane.com](http://trane.com) or [tranetechnologies.com](http://tranetechnologies.com).

---



The AHRI Certified mark indicates Trane U.S. Inc. participation in the AHRI Certification program. For verification of individual certified products, go to [ahridirectory.org](http://ahridirectory.org).

Trane has a policy of continuous data improvement and it reserves the right to change design and specifications without notice. We are committed to using environmentally conscious print practices.